

“국내 최초, 최대 용량” Dalim LH2 Tank Trailer 디엘 액화수소 트레일러

Global Partner of Transport & Storage!
수송과 저장의 글로벌 파트너!

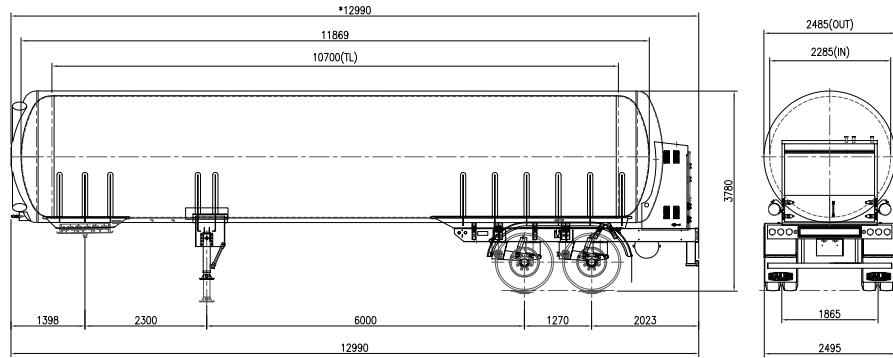

47KL LH2 Tank TRL 외관도



차량 관제 시스템 TONGSORI H

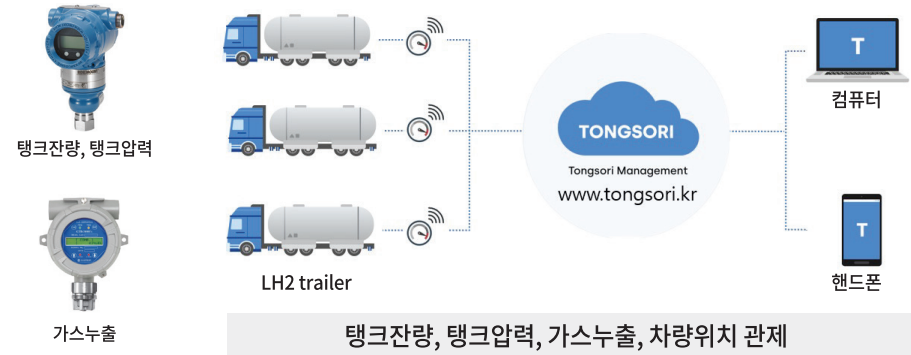

Technical Data_ 기술자료

Chassis(샤시)		Tank(탱크)	
Item(항목)	Specifications(제원)	Item(항목)	Specifications(제원)
Overall Length(전장)	12,990mm	Volume(용량)	47,000L
Overall Width(전폭)	2,495mm	Inner Tank Design Pressure(내탱크 설계압력)	1.2MPa
Overall Height(전고)	3,780mm	Outer Tank Design Pressure(외탱크 외부설계압력)	0.2MPa
Wheel Base(축간거리)	8,300 + 1,270 = 9,570mm	Inner/outer Tank Mat'l(내/외탱크 재질)	Stainless Steel
Curb Weight(공차 중량)	23,000kg	Insulation(단열방식)	Double Wallet Vacuum Insulation
Max.payload(최대적재량)	3,000kg	Design Temperature(설계온도)	-253 ~ +40°C
Gross Vehicle Weight(차량총중량)	26,000kg	Valve Type(밸브 형식)	Jacket Type
Spring(스프링)	Air Spring(공기스프링)	Piping(배관)	Vacuum Insulation
Brake(브레이크)	EBS(RSS, 전복방지장치)	Safety Device(안전장치)	OptiTire System(타이어공기압측정장치), TailGuard System(후방추돌방지장치)
Tire, Wheel	12R22.5, AL ALLOY	Monitoring System(Web, App 지원)	GPS, Tank Pressure & Level, Gas Detector